

# Student Manual

## Dock & Vessel Mounted



## Pedestal Crane Operator Safety Training



CH Crane & Rigging Consultants, Inc.  
277 Brazos Way Caldwell, TX 77836  
Office 979-272-0478 • Fax 979-272-0548  
Joe Cowen 979-203-3045 • Derek Henson 979-224-5029

## TYPES OF DOCK MOUNTED PEDESTAL CRANES

There are basically two types of hydraulic pedestal cranes used on docks.

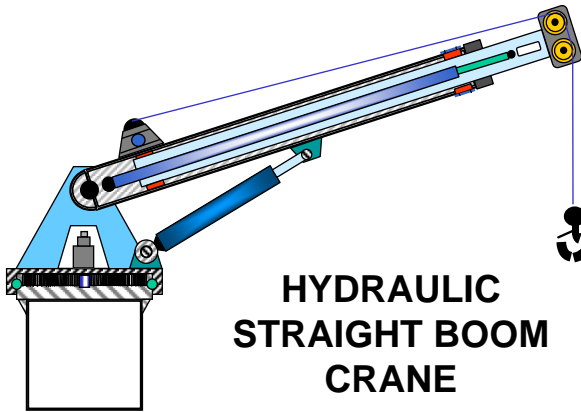

The first is the telescopic straight boom crane. Other than the normal features of a crane, the boom can be extended in and out. This feature allows the crane to reach out further and higher when the need arises.

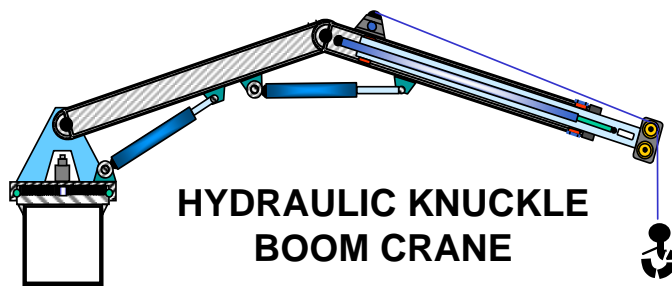

The second type of crane is the knuckle boom crane. This crane has two boom sections. The second boom section hinges at the tip of the first section. Each boom section can be operated independently of the other and this feature allows the operator to position the load more accurately. The second boom section may also be fitted with a telescopic section.

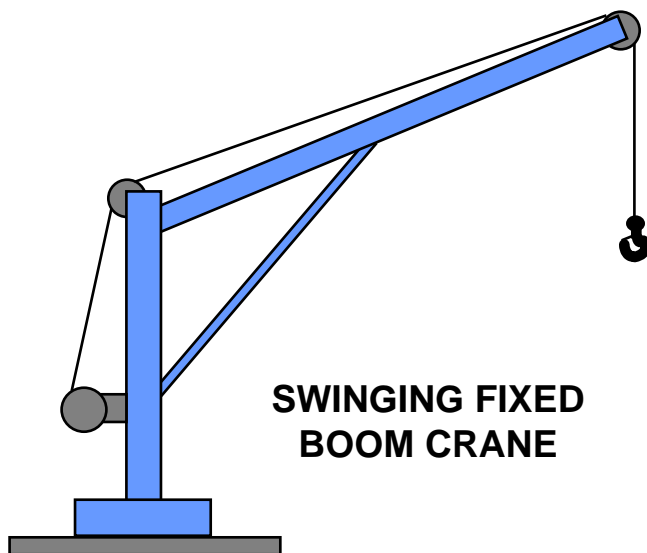

The swinging boom type of crane is the simplest crane found on most docks. It consists of a fixed length boom that is mounted on a vertical mast. The boom cannot be raised or lowered. Crane rotation is typically manual, by means of bar or pipe which is pushed or pulled to rotate the crane. The winch used to hoist the load is often electrically powered, with the up / down control mounted on the end of an electrical cord

# CRANE COMPONENTS

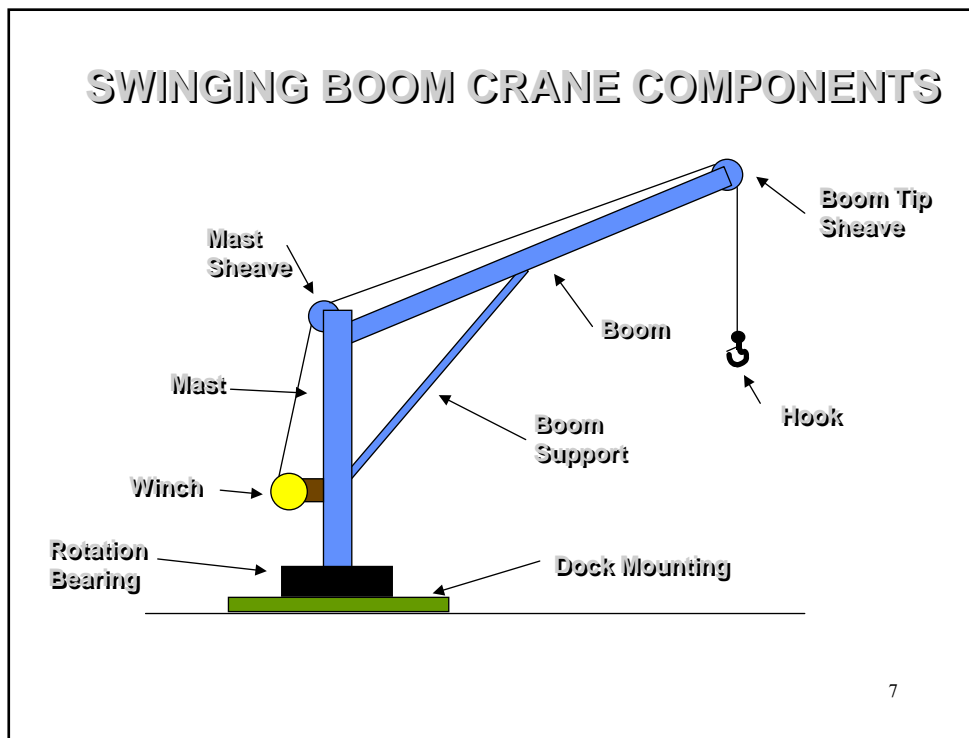
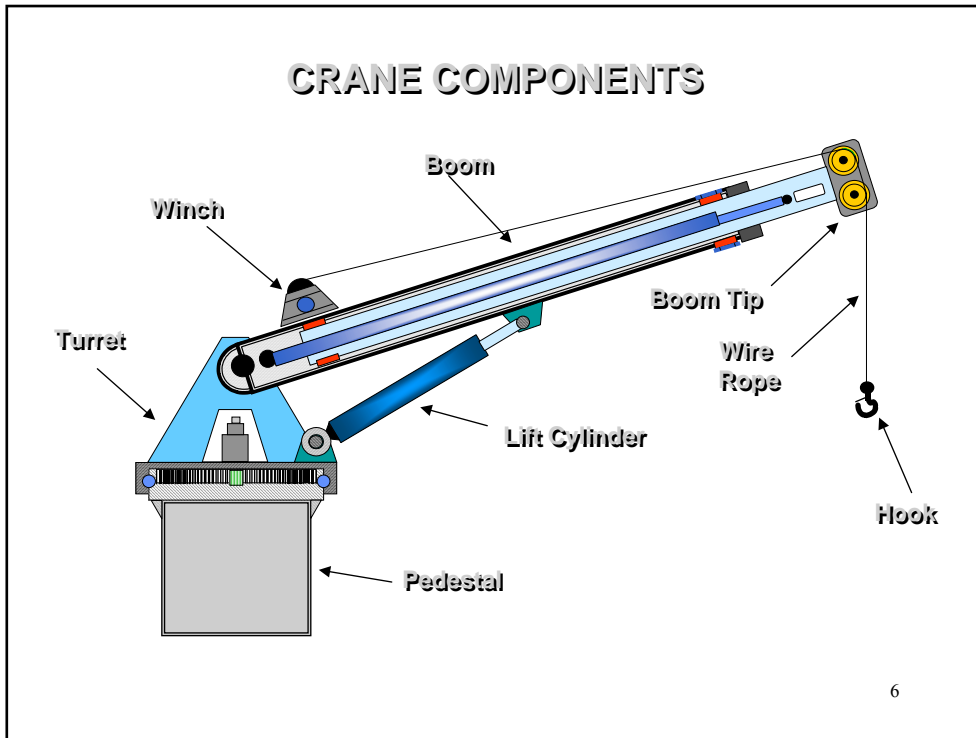

# CRANE INSPECTION

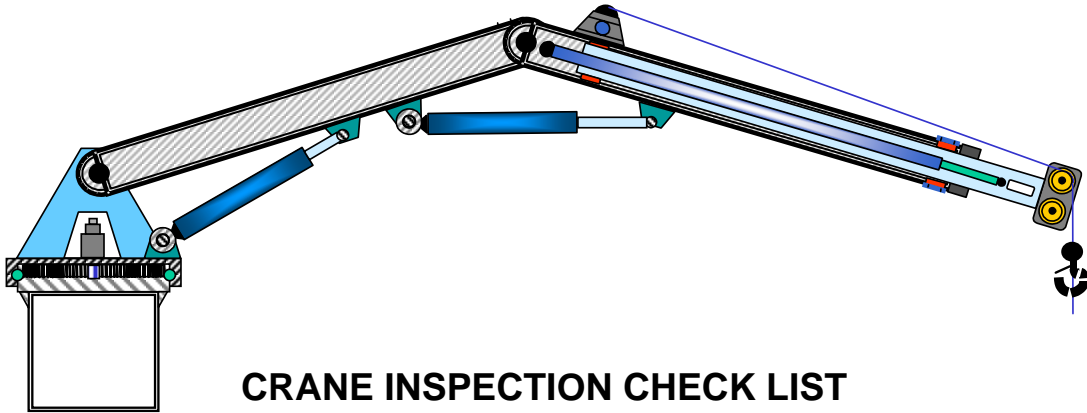

## CRANE INSPECTION CHECK LIST

INSPECTION AREA	INSPECTION RESULTS			Comments
	Sat.	Unsat.	N/A	
<b>Supporting Structure</b>				
Welds				
Bolts				
<b>Rotating System</b>				
Bull & Pinion Gear				
Swing Brakes				
Hydraulic Drive Motor				
<b>Boom</b>				
Welds				
Stress & Distortion				
Hinge Pin				
Boom Cylinder & Pins				
Wear Pads				
Telescopic Operation				
Tip Section & Sheaves				
Angle/Radius Indicator				
Anti-Two Blocking Sys.				
<b>Winch System</b>				
Wire Rope Condition				
Rope Reeving				
Mounting Bolts				
Brakes				
Functional Operation				
<b>Hydraulic System</b>				
Pump Performance				
Control Functions				
Control Markings				
Hydraulic Leaks				
Hose Condition				
Fluid Level				
<b>Load Block</b>				
Sheaves				
Pins				
Swivel				
Hook				

The operator is responsible for inspecting the crane prior to using it.

## TURRET INSPECTION

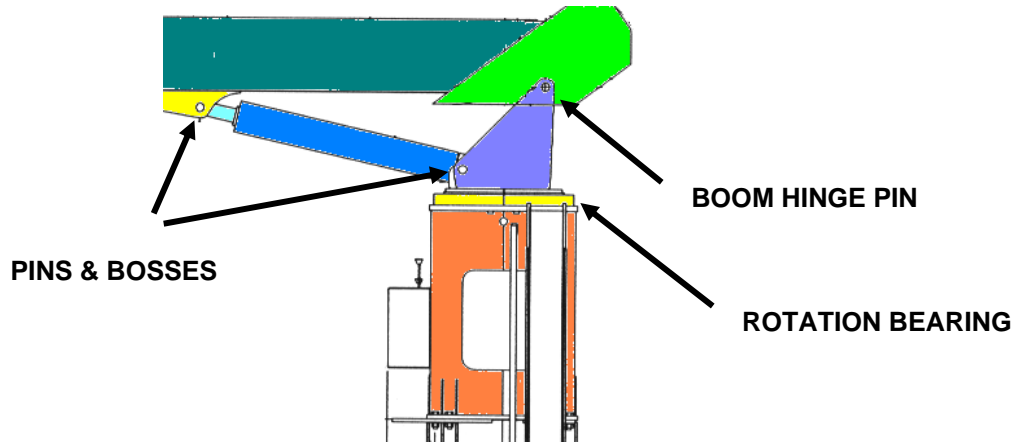

The four areas in the slide can be checked by performing the following test:

- Retract the boom fully and raise it to its most vertical position and extend the hoist wire about 10 feet.
- Abruptly lower the boom momentarily which will result in the turret and boom component rocking. Observe the movements in the rotation bearing, boom hinge pin and bushing, and the lift cylinder pins and bushings. **CAUTION: WHEN SHAKING THE CRANE, OBSERVE THE HOOK AND STOP ANY BOOM MOVEMENT IF IT CAN SWING INTO THE BOOM.**
- Any excessive movement must be noted and evaluated per the manufacturer's specifications.
- Check the turret area for cracked welds and any deformed components.

# ROTATION INSPECTION

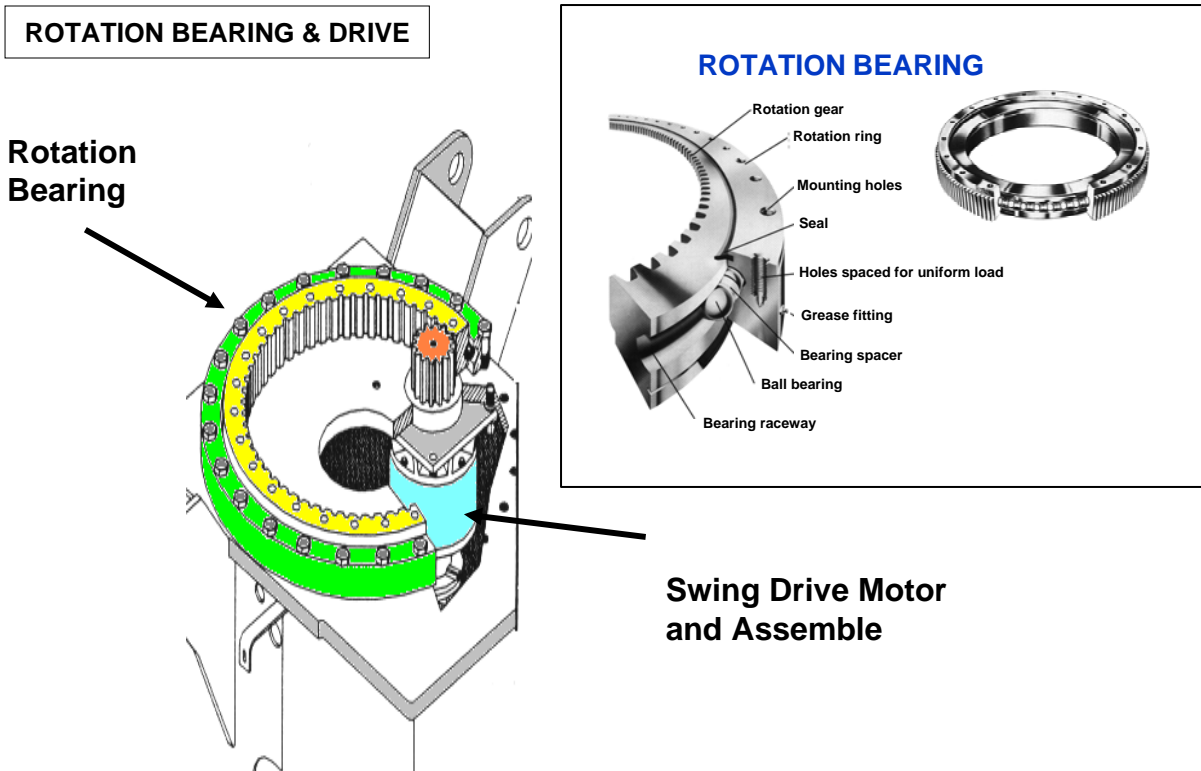

**The only thing that keeps the boom from detaching from the pedestal is the rotation bearing. If it fails, the boom comes down.**

- The rotation bearing should be greased on a regular basis per the manufacturer maintenance manual.
- The rotation bearing is attached to the pedestal by bolts. These need to be checked for tightness. The turret is also attached to the bearing with bolts and they also need to be checked.
- The rotation drive motor is typically mounted up in the pedestal and the mounting bolts need to be checked.
- Check the ring and pinion gears for grease.

## CRANE INSPECTION

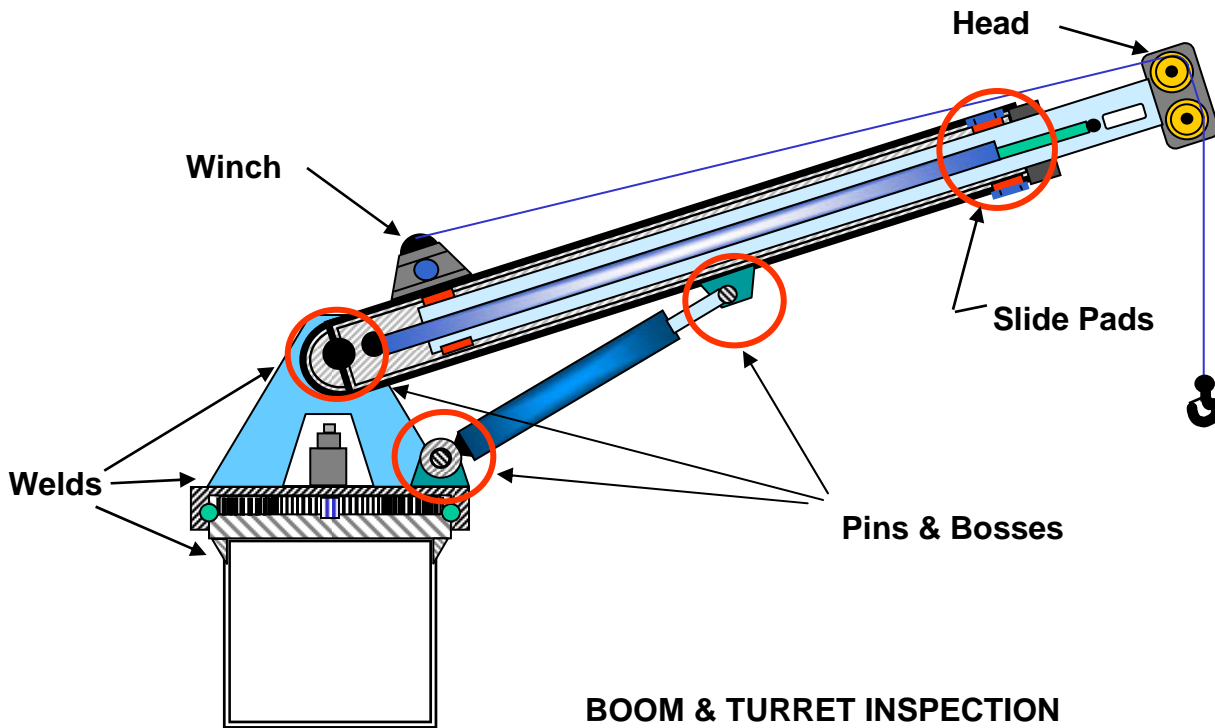

- The boom needs to be extended and checked for smoothness of operation. Any binding or difficulty in extending could be the result of damaged boom sections.
- All welds need to be checked for cracks.
- Any hydraulic leaks need to be investigated and repaired. Check the hoses for chaffing and wear.
- The slide pads can be checked for proper alignment by extending the boom completely and lowering the tip toward the ground. Move the boom tip back and forth by pushing on it and observe how much the boom sections move inside each other. Excessive movement will require the slide pads to be adjusted or replaced.
- The boom tip needs to be checked for deformation and twisting.
- The winch should be checked for proper reeving. The most common cause of damage to wire rope is crushing due to crossed wraps on the winch drum.

# CRANE INSPECTION

- Check sheaves for bearing wear and lubrication.
- Check the flanges and treads. Use a sheave gauge.
- Sheaves can only be repaired per manufacturer's procedures.

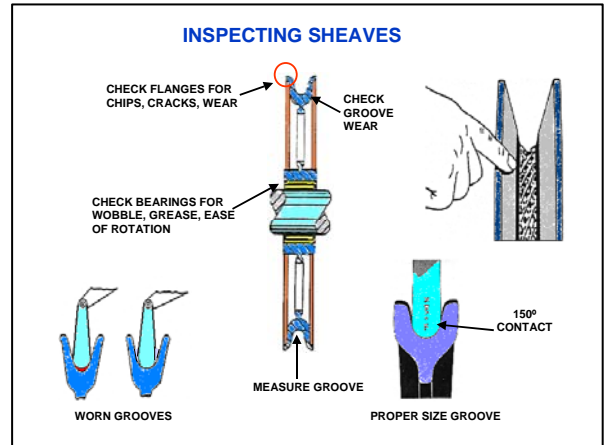

- The sheaves and bearings need to be checked on crane blocks.
- Check the side plates and any additional weights attached to the sides need to be checked for loose or missing bolts or fasteners.
- The hook and shank nut should be separated periodically and the threads inspected for corrosion and other damage.
- The safety latch must be in place and functioning properly.
- The hook should rotate freely on the swivel bearing. Check for excessive movement.

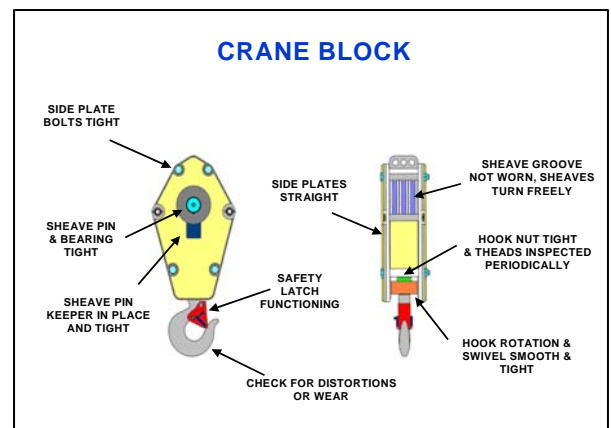

- Wear in excess of 5% in the neck of the hook and 10% in other areas is cause for removal.
- An increase in the hook throat opening of more than 15% is cause for removal
- Any twist in the hook of more than 10% is cause for removal.
- Hooks can only be repaired per manufacturer's procedures.

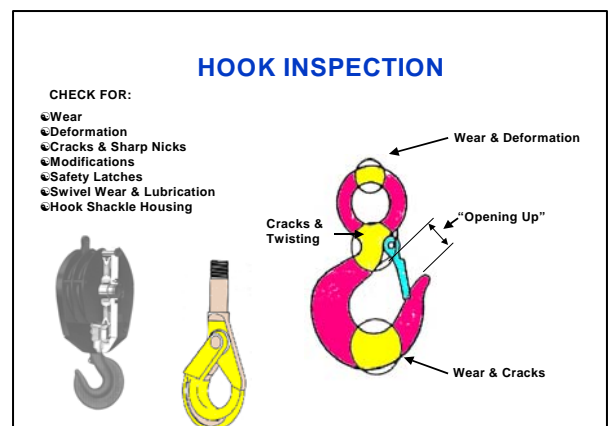



# WIRE ROPE INSPECTION

**Kinks** are a permanent distortion. After a wire rope is kinked it is impossible to straighten the rope enough to return it to its original strength. The rope must be replaced. Causes: crossed lines on drum, improper handling and installation, and uncoiling.

**KINKED WIRE ROPE**

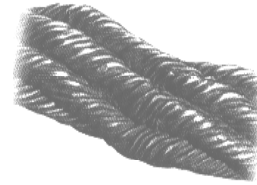

**Strand Nicking** is due to continued operation under a high load which results in core failure.

**STRAND NICKING**

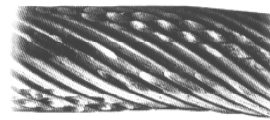

**Metal Fatigue** is usually caused by bending stress from repeated passes over sheaves, or from vibration such as crane pendants.

**FATIGUE FAILURE**



**Fatigue Breaks** can be either external or internal. They also can be caused by wobbly sheaves, tight grooves, poor end terminations. In the absence of all these causes, remember that all wire rope will eventually fail from fatigue.

**FATIGUE BREAKS**

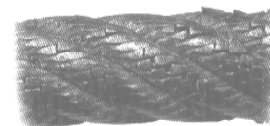

**Bird Caging** is a result of mistreatment such as sudden stops, wound on too tight of drum, or pulling through tight sheaves. The strands will not return to their original position

**BIRDCAGE**

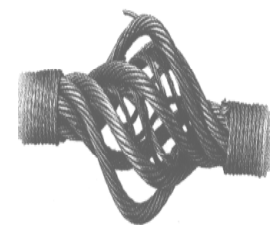

**High Stranding** is a condition caused when overloading and crushing take place and the other strands become overloaded.

**HIGH STRAND**



# DYNAMIC LOADING

## IMPACT OF DYNAMIC LOADING

When a load is moved, additional stresses are imposed on the crane's structure. To start a load moving either by hoisting, booming or swinging, the crane will have to exert an additional force. How much additional force is dependent on the weight of the load and how fast it has started moving. Loads started slowly and stopped slowly will not exert as much stress on the crane as those which are move rapidly.

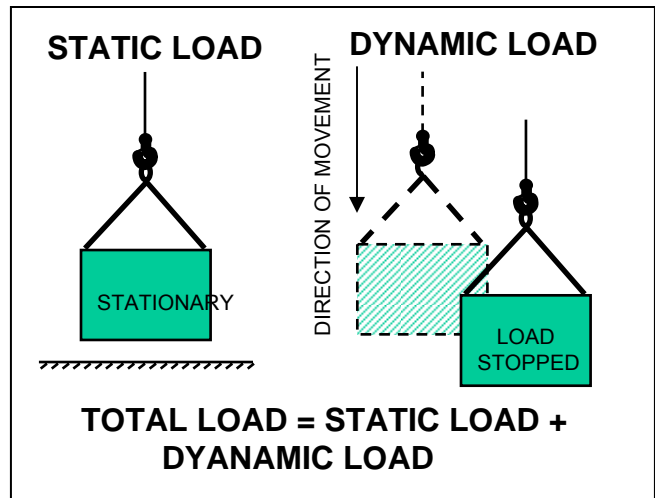

The below chart shows how the dynamic load increases as the rate of starting and stopping the load increases.

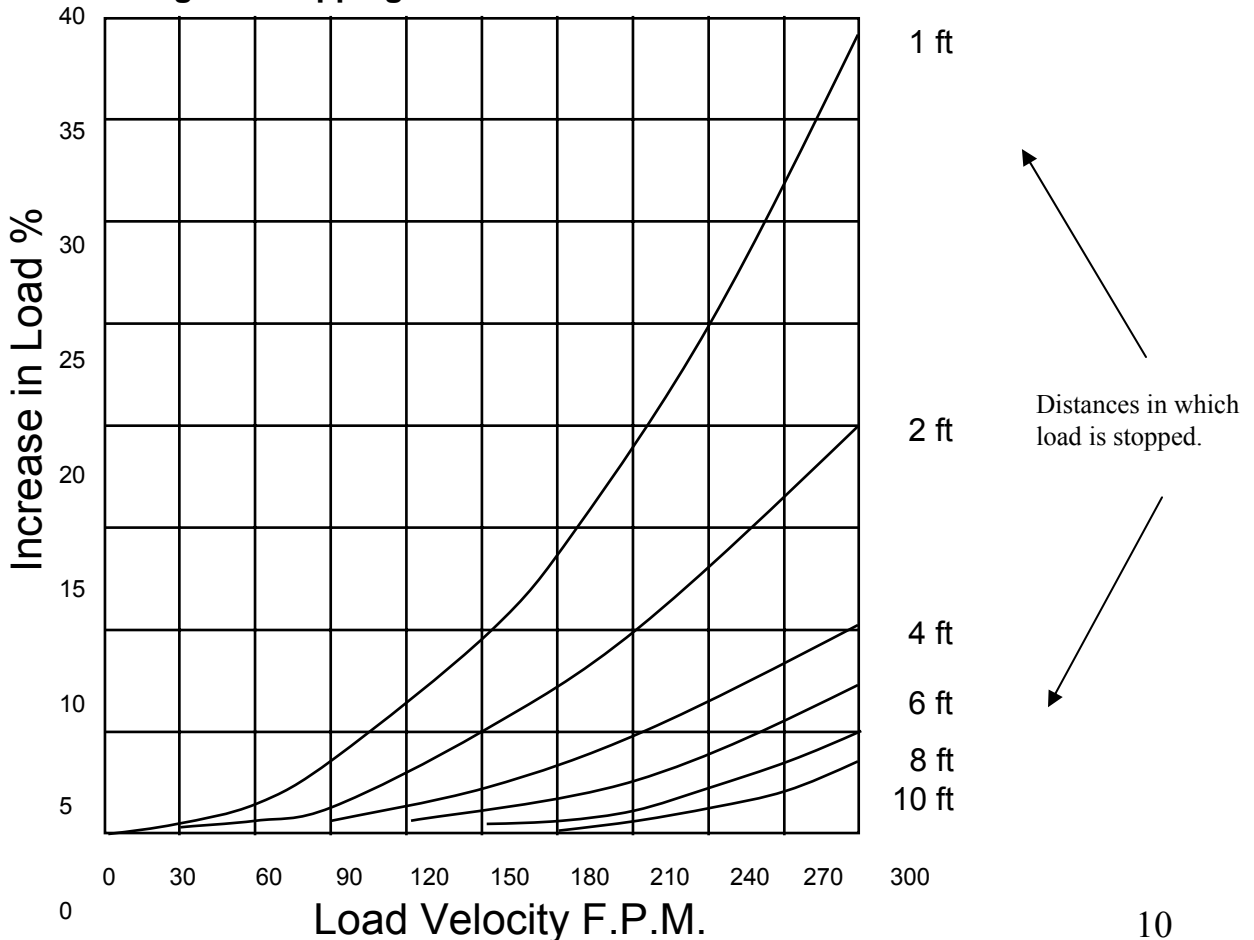

## SIDE LOADING

The boom is very susceptible to side loading damage and needs to be above the load at all times. Tilting up panels are a common cause of side loading. When tilting up a panel, the hoist line must remain vertical at all times. Although it is not very apparent, wind can cause excessive stresses on the crane. The operator must stop operations when the wind becomes a significant factor. The wind pressure on the load can also add side loading to the boom as well as losing control of the load. Tag lines may be necessary to help control the load, but should never be used to pull the load around.

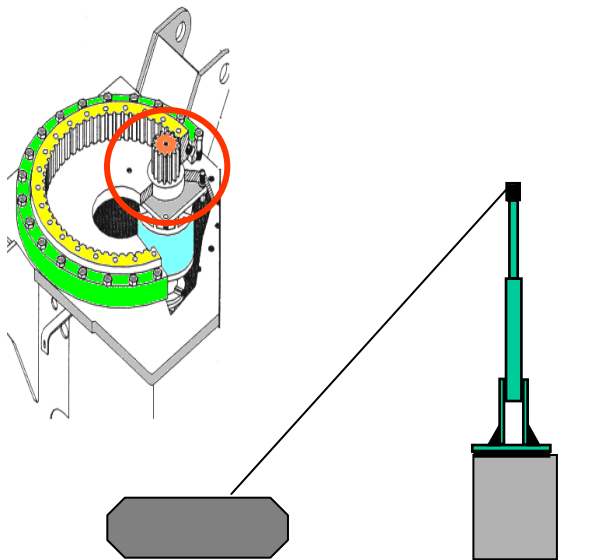
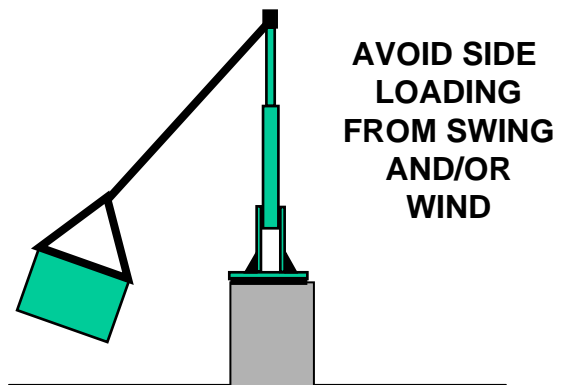
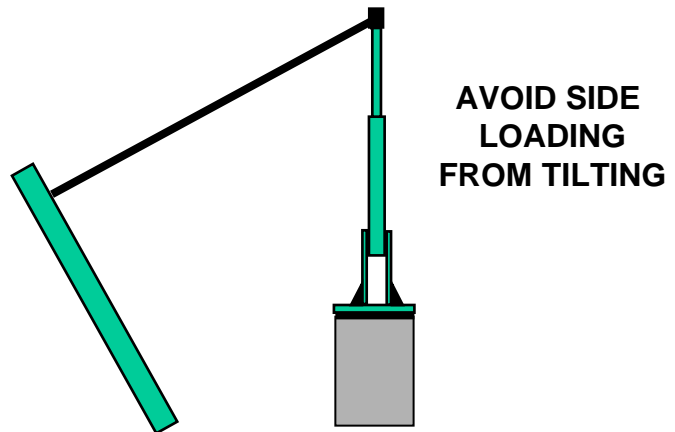

Never intentionally side load the crane by yarding or dragging a load on the ground. This could seriously damage the boom or swing mechanisms on the crane. Knuckle booms are particularly susceptible to damage from this practice. This puts tremendous strain on the pinion gear of the swing motor which over time could fail.

# LOAD CHART

## RANGE DIAGRAM

The range diagram shows the various boom tip heights based on boom length and radius. This chart will help to determine if this crane is able to make a certain lift.

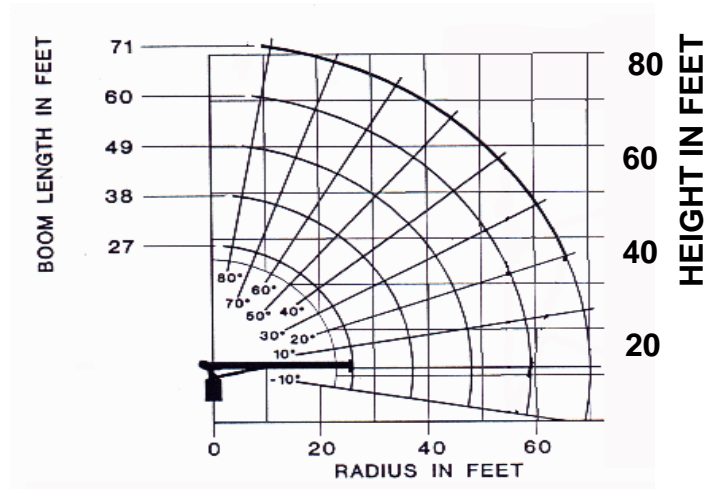

## RATED LOAD CAPACITY CHART

BOOM RETRACTED			BOOM EXTENDED		
BOOM ANGLE IN DEG.	LOAD DIST. IN FEET	LOAD CAP. IN POUNDS	BOOM ANGLE IN DEG.	LOAD DIST. IN FEET	LOAD CAP. IN POUNDS
63	10	24,000	79	10	16,000
47	15	17,170	73	15	12,800
30	20	13,140	68	20	9,700
1	22	10,700	58	25	8,250
			50	30	6,960
			45	35	5,900
			38	40	5,130
			27	45	4,500
			1	50	3,300

The load capacity section of the load chart states the lifting capacity of the pedestal crane for a given radius and boom length. A typical chart will show the radius in the left hand column and the corresponding boom angle and length on top. If the desired radius falls between two figures on the chart, the longer of the two must be used with their corresponding angles and capacities. Never try to “split the difference.” The boom angles on the chart are for **loaded** booms. When pre-determining where the boom angle is to be used as a means for establishing the radius, 2 degrees should be added to the load chart number. As the boom is loaded, it will tend to drop a few degrees, so the 2 degrees should compensate for that.

## CRANE SAFETY

- Do not leave the crane with a suspended load
- Rig the crane with sufficient parts of line for the load
- Avoid two-blocking the crane
- Always have a minimum of three wraps of cable on the drum
- Monitor the winch to make sure that it is spooling correctly
- Do not lift loads over personnel
- Lift one load at a time

## MAKING THE LIFT

Review the lift scenario with the operator, riggers and signal person

Attach taglines when necessary

Position signal person within visibility of the load and operator

Begin by lifting the load *slowly*

Re-check the boom angle indicator to assess radius increase

Keep load as low as possible when moving it

Swing *slowly* to avoid swing out.

Avoid erratic booming

Follow signal and stop operation when uncertain

Lower load *slowly*

## SIGNALS

- Only one person should be designated as the signal person.
- The emergency stop signal can be given by anyone on the site.
- The signals must be clear and precise.
- The crane operator should never respond to a signal that is not clearly understood.

## HAND SIGNALS



**DOG EVERYTHING**



**EXTEND BOOM**



**EMERGENCY STOP**



**LOWER THE LOAD  
RAISE THE BOOM**



**RETRACT BOOM**



**RAISE THE LOAD  
LOWER THE BOOM**



**RAISE THE LOAD**



**RAISE THE BOOM**



**SWING**



**LOWER THE  
LOAD**



**LOWER THE BOOM**



**STOP**

## SHACKLE INSPECTION

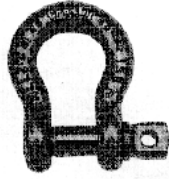

The working load limit (WLL) must be printed on the shackle or it must be taken out of service. This WLL is for vertical lifts only.

Only two types of shackles are to be used in rigging for lifts. The screw pin type and the bolt type shackle.

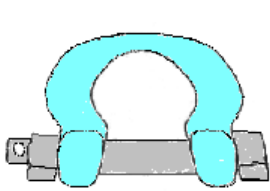

Shackles that are deformed or damaged must be removed from service.

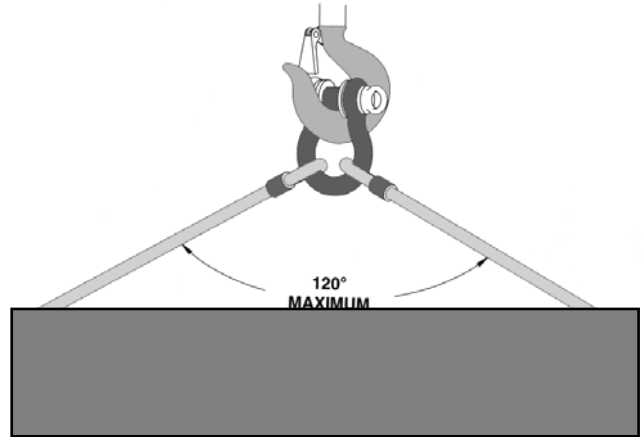
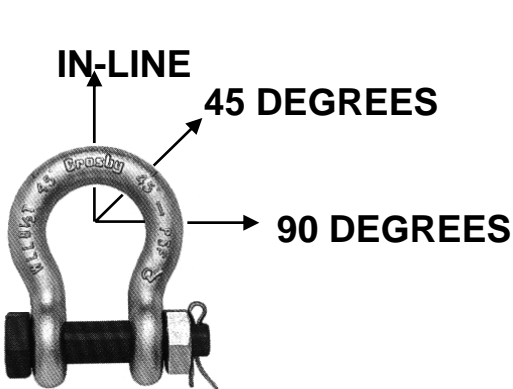

<b>Side Loading Reduction Chart For Screw Pin &amp; Bolt Type Shackles Only†</b>	
<i>Angle of Side Load</i>	<i>Adjusted Working Load Limit</i>
<b>0° In-Line</b>	<b>100% of Rated Working Load Limit</b>
<b>45° from In-Line</b>	<b>70% of Rated Working Load Limit</b>
<b>90° from In-Line</b>	<b>50% of Rated Working Load Limit</b>

**† DO NOT SIDE LOAD ROUND PIN SHACKLES**

## EYE BOLTS

Eye bolts should always be inspected before use. Look for signs of wear and damage. Look to see if shank is bent or elongated. Make sure the threads on the shank and the receiving hole are clean.

DIRECTION OF PULL	ADJUSTED WORKING LOAD
In-Line	Full Rated Working Load
45 Degrees	30% of Rated Working Load
60 Degrees	60% of Rated Working Load

- Always use Shouldered Eye Bolts for angular lifts.
- For angular lifts, reduce working load according to chart.
- Never exceed load limits.
- Always screw eye bolt down completely for proper seating.
- Always tighten nuts securely against the load.
- Always stand clear of load when lifting.
- Always lift load with steady, even pull-do not jerk.
- Do not reeve slings from one eye bolt to another.
- Never machine, grind or cut the eye bolt.

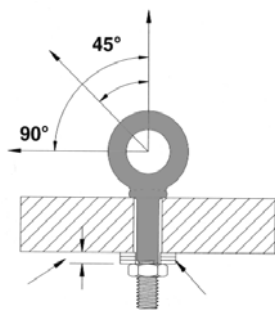

Shoulder Nut  
Eye Bolt

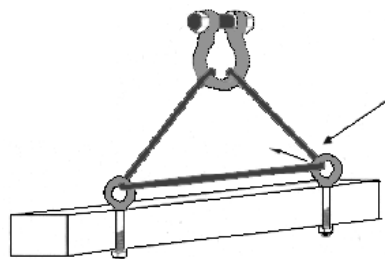

**WRONG!**

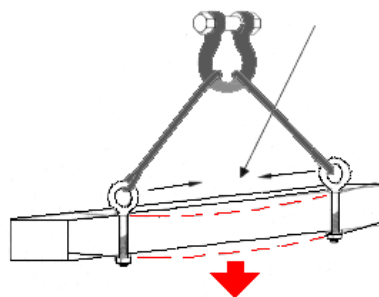

**CAUTION**

**STRUCTURE MAY BUCKLE FROM  
COMPRESSION FORCES**



# WIRE ROPE SLING INSPECTION

- KINKING
- CRUSHING
- UNSTRANDING
- BIRDCAGING
- STRAND DISPLACEMENT
- CORE PROTRUSION
- CORROSION
- BROKEN OR CUT STRANDS
- BROKEN WIRES

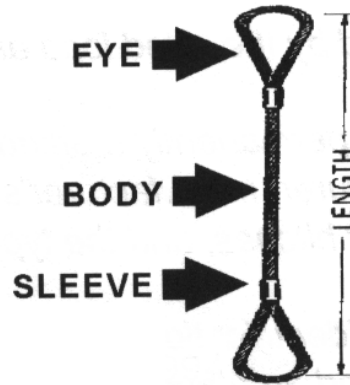

Wire rope slings need to be inspected in the same way wire rope is and a **record kept of those inspections**. All slings must have a tag on them indicating the capacity or they must be taken out of service.

Chain slings are to be inspected regularly and a record kept of these inspections also. Again, if there is no capacity tag, it must be taken out of service. Chain slings are often used to hold steel while it is being welded. Always check to make sure heat damage has not occurred. Heat damage can be detected by discolored metal.

## CHAIN SLINGS CAUSE FOR REMOVAL DEFORMATION AND STRETCH



## CHAIN SLINGS CAUSE FOR REMOVAL WEAR

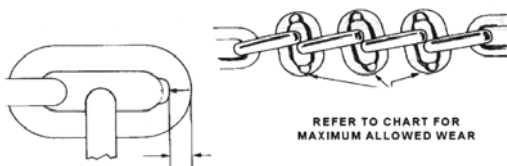

## CHAIN SLINGS CAUSE FOR REMOVAL CRACKS, NICKS AND GOUGHES



SHARP TRANSVERSE NICKS AND GOUGHES SHOULD BE ROUNDED OUT BY GRINDING, DO NOT EXCEED WEAR ALLOWANCE

## SYNTHETIC SLING INSPECTION

Far too many web slings have to be discarded prematurely simply because abusive or careless work habits caused irreparable damage.

**To the right are some examples of damaged slings.**

Regardless of whether a sling shows damage from abuse or regular wear, the overriding rule in all cases is that the sling eyes should be cut, and the sling discarded immediately whenever damage is detected.

**When using synthetic slings, remember:**

- Slings without a capacity tag should be discarded. That tag should have the following information:
  - Name and trademark of manufacturer.
  - Manufacturer's code or stock number.
  - Rated loads (rated capacities) for the type of hitches used.
  - Type of synthetic material.
- Use wear pads on corners to protect the sling from cuts, or abrasions.
- Do not pull the sling out from under the load if caught under it.
- Take into consideration the sling angles when calculating the capacity of the sling to handle the load.

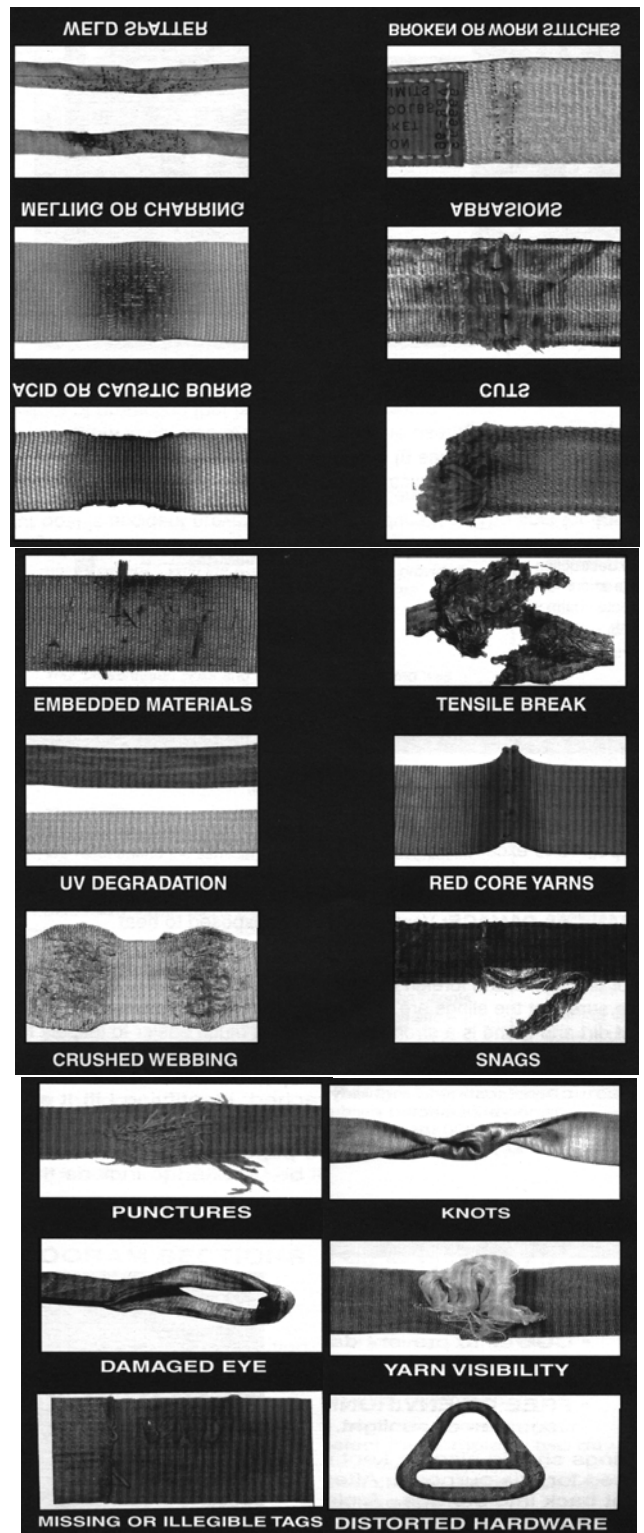

# SLING ANGLES

When slings are brought together and form a hitch, as shown at right, the stresses in the slings increase and a compression force on the load is created. As the sling angle decreases, the stresses in the sling and on the load increase.

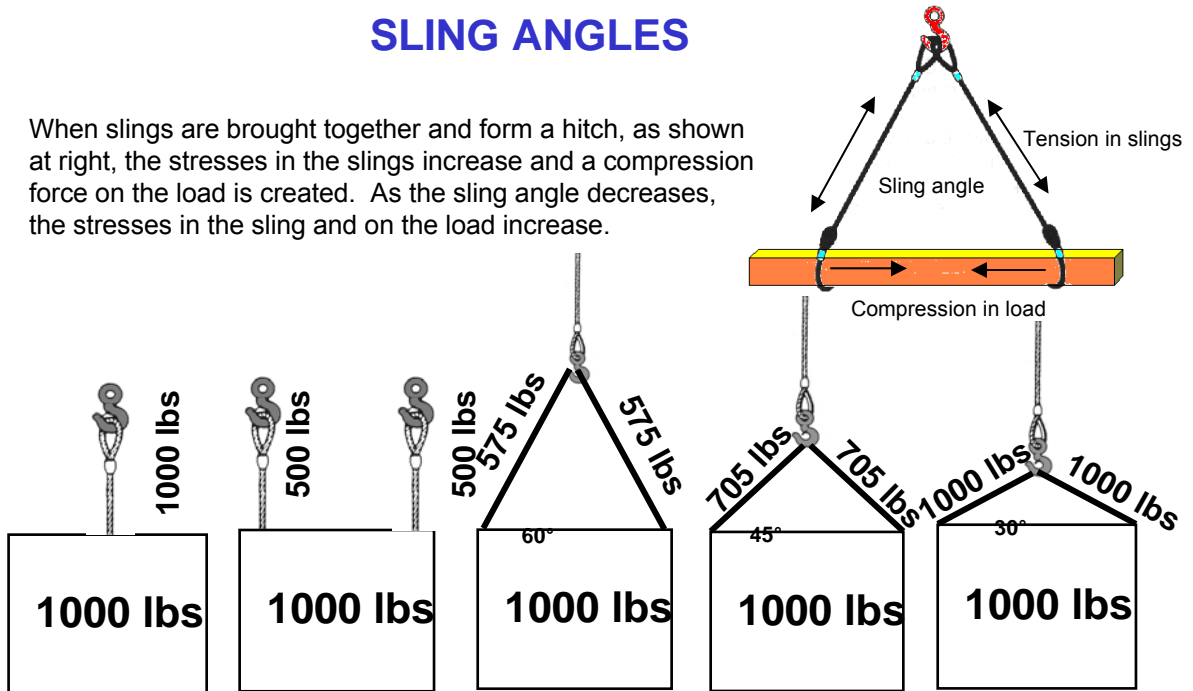

Sling angles of 60 degrees are the best to use because of the minimal increase of stress in the slings. When required to use smaller sling angles, slings need to be selected based on the increased stress and not on the weight of the load. The compression in the load also has to be considered. When the sling angle is 30 degrees for a 1000 lb load, the compression which is crushing the load will be 866 lbs. Depending on the structural strength of the load, it may be damaged.

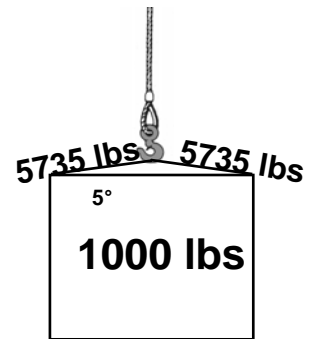

All that is needed to calculate the stress in a sling is the weight of the object and a measuring tape.

**Load in each sling =**  
**500 x Load Angle Factor**

Slings Angle Degree (A)	Load Angle Factor = L/H
90	1.000
60	1.155
50	1.305
45	1.414
30	2.000

**Load On Each Leg Of Sling = (Load/2 x Load Angle Factor)**

### Example:

If the sling was 8' long and the height (H) was 4', then 8 divided by 4 equals 2 which equals the **Load Angle Factor**. So, if the load is 1000lbs, each sling is required to support 500lbs. The stress in the sling is equal to 500lbs x the load angle factor of 2 or 1000lbs.

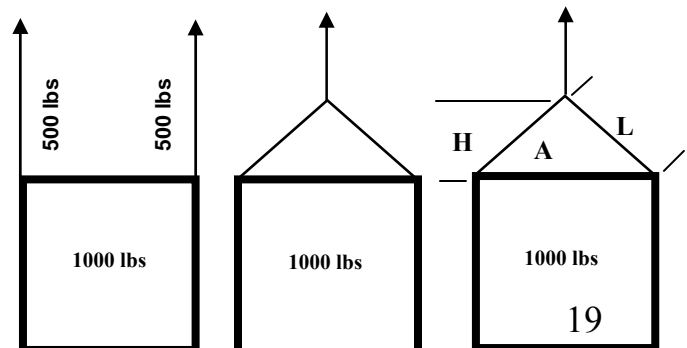

# Calculating Load Weight

To find the weight of any item you need to know its volume and unit weight.

- Volume x Unit weight = Load weight
- Unit weight is the density of the material

Here are some examples of common materials and their unit weight:

## WEIGHTS OF MATERIALS BASED ON VOLUME (lbs. per cubic ft.)

MATERIAL	UNIT WEIGHT	MATERIAL	UNIT WEIGHT
<b>METALS</b>		<b>TIMBER</b>	
Aluminum	165	Cedar	34
Brass	535	Cherry	36
Bronze	500	Fir, seasoned	34
Copper	560	Fir, wet	50
Iron	480	Hemlock	30
Lead	710	Maple	53
Steel	490	Oak	62
Tin	460	Pine	30
<b>MASONARY</b>		Poplar	30
Ashlar masonry	160	Spruce	28
Brick, soft	110	White pine	25
Brick, pressed	140	Railroad ties	50
Clay tile	60	<b>LIQUIDS</b>	
Rubble masonry	155	Diesel	52
Concrete, cinder, haydite	110	Gasoline	45
Concrete, slag	130	Water	64
Concrete, stone	144	<b>EARTH</b>	
Concrete, reinforced	150	Earth, wet	100
<b>MISC.</b>		Earth, dry	75
Asphalt	80	Sand and gravel, wet	120
Glass	160	Sand and gravel, dry	105

# Calculating Load Weight

## Calculating Volume

### Volume of a Cube

Length x Width x Height = Volume

$$8 \text{ ft} \times 4 \text{ ft} \times 2 \text{ ft} = 64 \text{ cubic feet}$$

If the material was **cedar**, then all we need to do to determine it's weight would be to multiply the unit weight of cedar x 64.

Unit weight x Volume = Weight

$$34 \text{ lbs per cubic foot} \times 64 \text{ cubic ft.} = 2,176 \text{ lbs.}$$

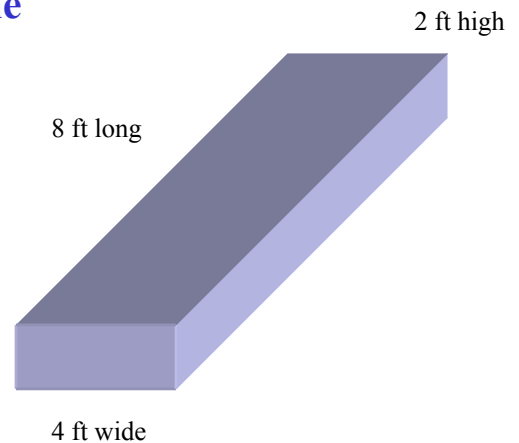

### Volume of a Cylinder

Pi ( $\pi$ ) x Radius Squared x Length = Volume

$$\pi = 3.14$$

$$3.14 \times 1^2 \text{ ft} \times 10 \text{ ft} = 31.4 \text{ cubic ft}$$

If the material was **reinforced concrete**, then all we need to do to determine it's weight would be to multiply the unit weight of reinforced concrete x 31.4.

$$150 \text{ lbs per cubic foot} \times 31.4 \text{ cubic ft.} = 4,710 \text{ lbs.}$$

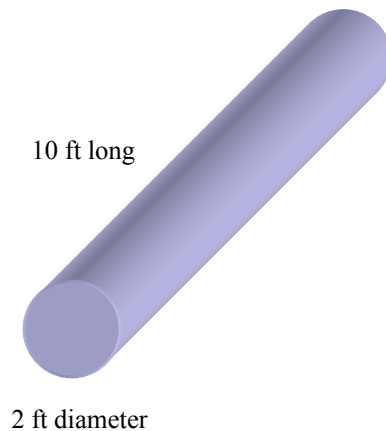

# Calculating Load Weight

## Volume of Pipe

Calculating the volume of pipe is a bit trickier but it is just simply subtracting the volume of the hole from the volume of the pipe.

If the pipe were one inch thick, three feet in diameter and 8 feet long, then we would figure the volume of the entire pipe and subtract the volume of the hole to get the the volume of the material.

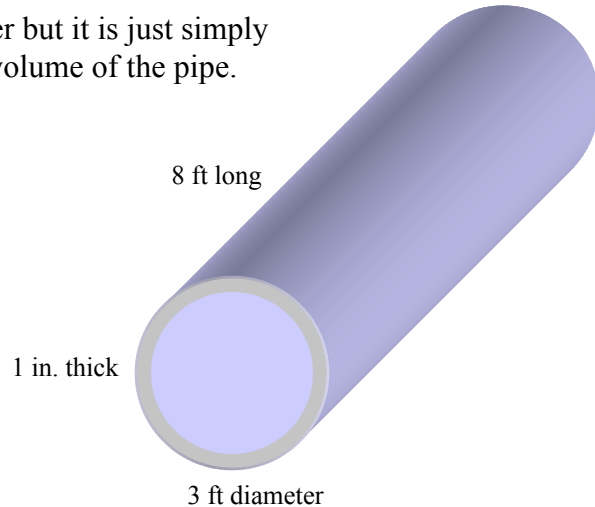

$$3.14 \times (1 \frac{1}{2} \text{ ft.})^2 \times 8 \text{ feet} = \text{total volume of pipe (56.52 ft}^3\text{)}$$

$$3.14 \times (1 \text{ ft } 5 \text{ in.})^2 \times 8 \text{ feet} = \text{volume of hole (50.41 ft}^3\text{)}$$

$$56.52 \text{ ft}^3 - 50.41 \text{ ft}^3 = 6.11 \text{ ft}^3$$

Volume of material x unit weight = total weight

If this pipe were **steel** then the unit weight would be 490 lbs.

$$6.11 \times 490 \text{ lbs} = 2,994 \text{ lbs.}$$

**For thin pipe** a quick way to **\*ESTIMATE** the volume is to split the pipe open and calculate the volume like a cube. The formula would be:

$\pi \times \text{diameter} = \text{width}$ , so:

$\pi \times \text{diameter} \times \text{length} \times \text{thickness} \times \text{unit weight} = \text{weight of object}$

$$3.14 \times 3 \text{ ft} \times 8 \text{ ft} \times 1/12 \text{ ft (or .008 ft)} \times 490 \text{ lbs} = \text{*3,077.2 lbs}$$

# Calculating Load Weight

## WEIGHT TABLES

Weight tables are an excellent way to calculate load weight. If you are handling certain materials often, then having a chart that gives you the weight per cubic foot, cubic yard, square foot, linear foot or per gallon is handy. Here are a few examples:

### METAL PLATES

1 INCH STEEL PLATE weighs approximately 40 lbs per sq. ft.  
1/2 inch steel plate would then be about 20 lbs. per sq. ft.

A steel plate measuring 8 ft. x 10 ft. x 1 inch would then weigh about 3,200 lbs. (8 x 10 x 40 lbs = 3,200 lbs.)

### BEAMS

Beams come in all kinds of materials and shapes and lengths. STEEL I-BEAMS weigh approximately 40 lbs a linear ft. at 1/2 inch thick and 8 inches x 8 inches. If it were 1 inch thick then it would be 80 lbs a linear ft. If it were 20 feet long at 1 inch thick then it would weigh about 1,600 lbs. (20 ft. x 80 lbs. = 1,600lbs.)

**There are weight tables for everything from creosoted pine poles to steel coils. Take advantage of these. But, if you don't know for sure the weight of a load and there are no other resources available to help you, don't hesitate to do the calculations yourself.**

# Calculating Load Weight Review

**USING THE FORMULAS AND WEIGHT TABLES FROM THE PREVIOUS PAGES, CALCULATE THE WEIGHT OF THE FOLLOWING OBJECTS:**

- 1. A load of cedar 4" x 4" x 8' posts. The stack is 3' high and 4' wide.**
  - a. 6,528 lbs.
  - b. 3,264 lbs.
  - c. 1,632 lbs.
  - d. not enough information was given.
  
- 2. A concrete pipe 1' thick, 4' in diameter and 12' long.**
  - a. 33,930 lbs.
  - b. 8,482 lbs.
  - c. 16,965lbs.
  - d. 1,696.5 lbs.
  
- 3. A steel plate that is 1" thick x 8' x 12'.**
  - a. 3,840 lbs.
  - b. 6,550 lbs.
  - c. 1,920 lbs.
  - d. none of the above.
  
- 4. An 1" thick I-beam that is 8" x 8" x 12 ft long.**
  - a. 9,600 lbs.
  - b. 6,300 lbs.
  - c. 1,820 lbs.
  - d. 960 lbs.





A CH-ENTERPRISES COMPANY